

0.37 Kw

50/60Hz
230V



Sfogliatrice verticale compatta da tavolo indicata per la laminazione della pasta in genere, delle piadine, della pizza tradizionale e al taglio. I 3 cilindri ed il piano intermedio consentono 2 passate in un unico ciclo, consentendo tempi di laminazione più rapidi. Struttura in acciaio inox. Adatta a panetterie, pasticcerie, ristoranti, comunità e pizzerie

Compact table-top vertical sheeter suitable for laminating traditional and sliced pizza and dough in general. The 3 cylinders and the intermediate table allow 2 passes per cycle, which ensures faster laminating times. Stainless steel structure. Suitable for bakeries, pastry shops, restaurants, community centres and pizzerias

Laminadora vertical compacta para banco indicada para la laminación de la masa en general, para la pizza tradicional y de corte. Los 3 cilindros y el plano intermedio permiten 2 pasos en un ciclo único, permitiendo tiempos de laminación más rápidos. Estructura de acero inoxidable. Apta para panaderías, pastelerías, restaurantes, comunidades y pizzerías

Laminoir vertical compact à table, idéale pour le laminage de la pâte en général, pour la pizza traditionnelle et en tranches. Les 3 cylindres et le plan intermédiaire permettent de laminer la pâte deux fois dans un seul cycle en garantissant des temps de laminage plus rapides. Structure en acier inox. Idéale pour les boulangeries, les pâtisseries, les restaurants, les communautés et les pizzerias

Компактная вертикальная настольная тестораскаточная машина, предназначена для раскатки различных видов теста, а также теста для традиционной и порционной пиццы. Три цилиндра и промежуточный рабочий стол позволяют выполнить 2 проката за один цикл и сократить время процесса раскатки. Корпус из нержавеющей стали. Предназначена для пекарен, кондитерских, ресторанов, общественных заведений и пиццерий

	RV50
Larghezza cilindri - Roller width	500 mm



Specifiche tecniche / Technical specifications

× Standard ○ Optional

	RV50	SHV	S5BM	SH50B-SH60B	SH500-SH600	SH6002	R62 R62-T	R65 R65-T	R65S R65S-T	R65A R65A-T	R65AX R65AX-T	EUROSTAR
Inversione ciclo con joystick Joystick cycle reversal			×	×	×							
Inversione ciclo con barra Bar cycle reversal						×						
Inversione ciclo con impulso elettrico Electric cycle reversal							×	×	×			
Inversione ciclo a pedale Pedal cycle reversal					○		○	○				
Tavoli removibili Removable tables						×	× ⁽¹⁾	× ⁽¹⁾	× ⁽¹⁾	× ⁽¹⁾	× ⁽¹⁾	× ⁽¹⁾
Sfarinatore automatico Automatic flour duster								○	○	○	×	×
Avvolgitore automatico Automatic reeler								○ ⁽²⁾	○	○	×	×
Regolazione velocità con Inverter Inverter speed regulation		×		○	○	○	○ ⁽³⁾	○ ⁽³⁾	×	×	×	×
Unità di taglio Cutting unit						○	○ ⁽³⁾	○ ⁽³⁾	○ ⁽³⁾	○ ⁽³⁾	○ ⁽³⁾	○
Carrello Trolley				○								
Ripiano intermedio con bacinelle Shelf with basins							○ ⁽¹⁾	○ ⁽¹⁾	○ ⁽¹⁾	○ ⁽¹⁾		
Kit 2 tavoli intermedi con bacinelle Kit 2 intermediate shelves with basins											○	

(1) Con alcune limitazioni / **With some limitations** - (2) Solo modelli con inverter / **Inverter models only** - (3) Standard su versioni T / **Standard on T version**



RV50

SHV

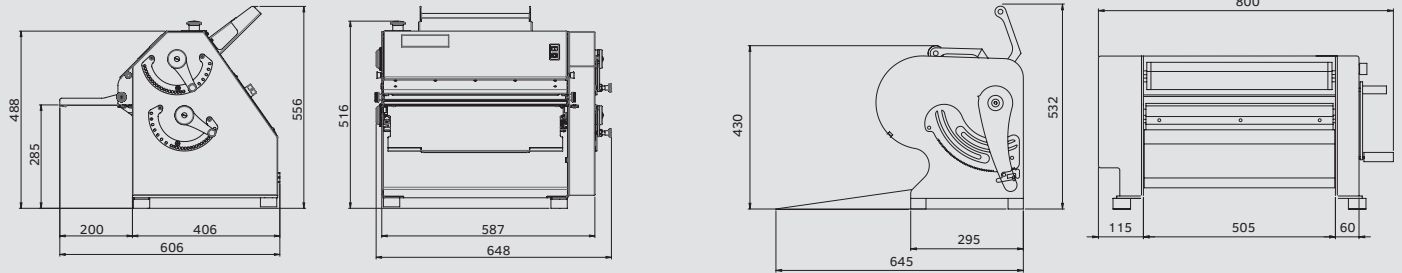

KG 85 Kg

KG 70 Kg

S5BM

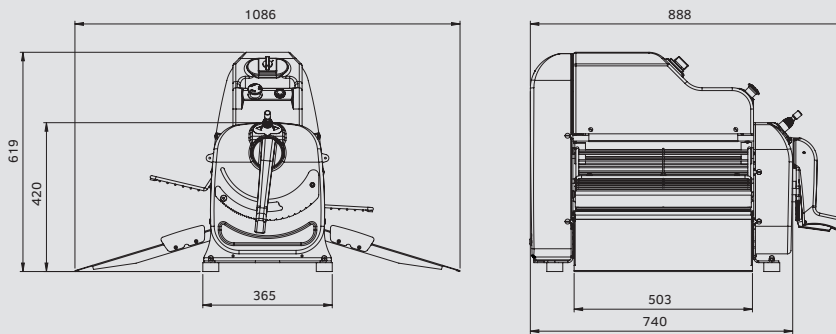

KG 81 Kg

SH50B / SH60B

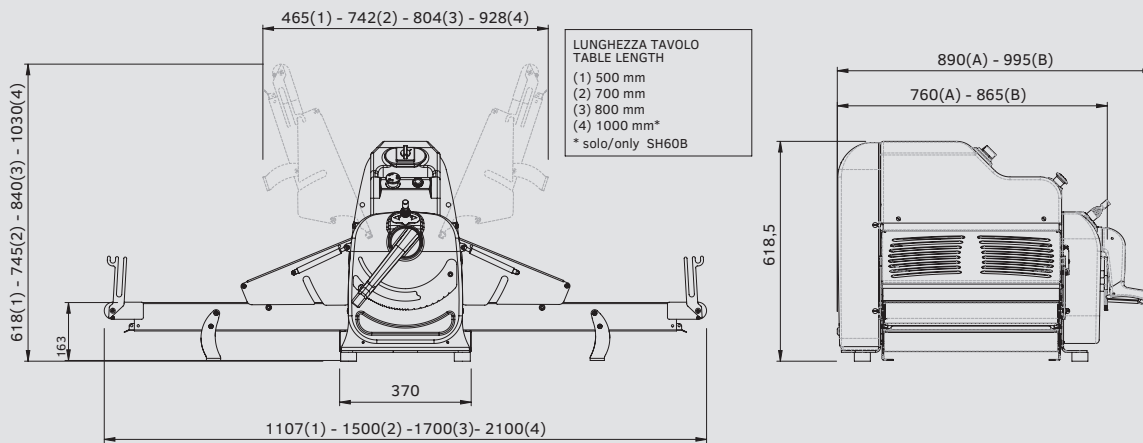

KG 91 ÷ 120 Kg